



**Parts Dept**

Sharon CT 06069

**Tel:** (800) 245-8222

Sales@partsdeptonline.com

www.partsdeptonline.com

## Interpuls Pulsator Repair & Maintenance

Parts Dept recommends installing a repair kit every 1500 hours or (12-18 months), the following instructions are designed to help in the installation of the repair kit and includes some routine maintenance guidelines.



### Specifications

Parts Dept's Interpuls pulsator is an alternating pulsator (easily converted to single shot by installing a single shot plug #62812) designed for operation at 12"-15" Hg.

Ratio's of 50:50, 60:40 and 70:30 are made possible by changing a slide on the inside of the pulsator. Speed is adjustable to a maximum of 60 pulsations per minute (120 single shot). Unless otherwise requested the pulsator is shipped from the factory at 60:40 ratio and 50 pulsation per minute (100 single shot).

### How it works.

The Interpuls pulsator creates pulsation by transferring air from one side of the pulsator to the other: Rubber diaphragms enclose each side of the pulsator. The milking systems vacuum removes air from one side of the pulsator while the other side is sealed off by the slide. This creates a pressure imbalance between the two sides. When the imbalance reaches a certain level, the slide snaps along a stainless steel shaft creating a single pulsation. As the slide moves, it simultaneously opens a duct, allowing air to enter the side of the pulsator under vacuum and seals the other side, allowing vacuum to build up and a new cycle is repeated.

The size and shape of the slide determine the ratio. Speed is determined by the volume of air that flows through the air duct when the slide moves from side to side. A set screw at the back of the pulsator controls this air volume and hence the pulsators speed.

Note: The set screw has a very sensitive adjustment. A quarter turn will create a few pulsations a minute difference.



**Parts Dept**  
Sharon CT 06069

**Tel:** (800) 245-8222

Sales@partsdeptonline.com  
www.partsdeptonline.com

## Interpuls Pulsator Parts List

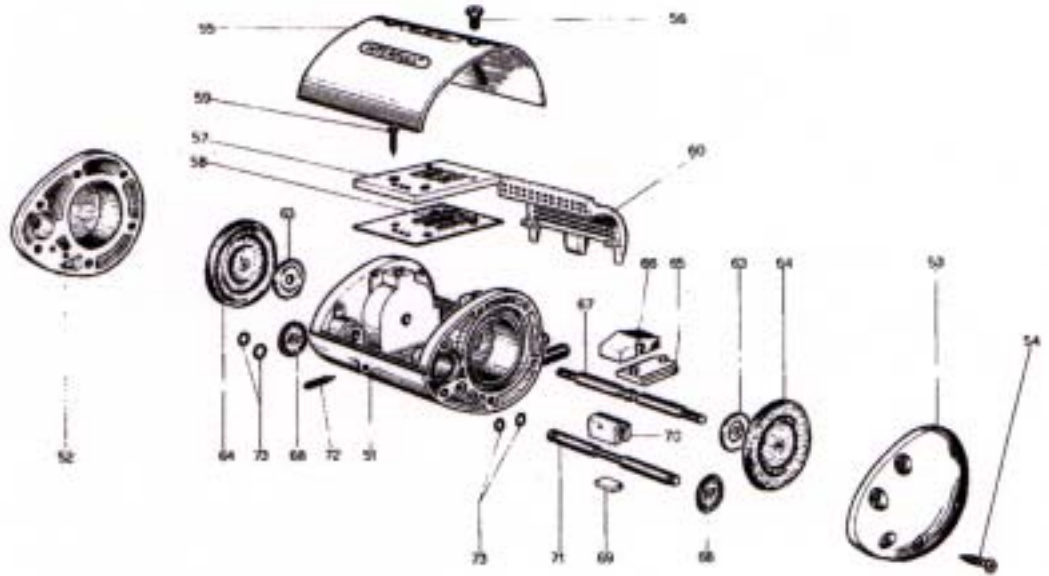

Drawing Number	Part Number	Description	Price
51	947091	Housing	\$79.00
52	947115	Cover (Left)	\$26.50
53	947116	Cover (Right)	\$26.50
54	947092	Side Cover Screws	\$ 0.50
55	63400	Top Cover	\$27.00
56	947093	Top Cover Screws	\$ 0.50
57	63217	Base Plate	\$39.95
58	63466 (D)	Base Plate Gasket	\$13.95
59	947096	Base Plate Screws	\$ 0.50
60	62764	Screen Filter	\$ 5.95
63	62720	Diaphragm Plate	\$ 2.95
64	62718 (D,E)	Diaphragm (Large)	\$ 4.95
65	62721 (D)	Ratio Slide (60:40)	\$ 7.95
65	63401 (D)	Ratio Slide (70:30)	\$ 7.95
65	62711 (D)	Ratio Slide (50:50)	\$ 9.95
66	63402 (D)	Slide Cover (Bringer)	\$ 6.50
68	62719 (D,E)	Pilot Valve Diaphragm	\$ 3.90
69	62723	Pilot Side (Bottom)	\$ 9.00
70	62722	Pilot Side (Top)	\$ 3.95
71	947108	Pilot Shaft	\$21.00
72	62714	Speed Valve	\$ 3.95
73	63218 (D,E)	Sealing Ring	\$ 0.55
Not Shown	62812	Single Shot Plug	\$ 1.50
Not Shown	63404 (D)	Allen Wrench	\$ 2.35
Not Shown	62769	Molded Felt Filter	\$11.50
Not Shown	62798 (D)	Thin Felt Filter	\$ 1.00

### (D) Deluxe Kit

1 x 63466 2 x 62718 1 x 63401 4 x 63402  
2 x 62719 4 x 63218 2 x 62798 1 x 63404

### (D) Economy Kit

2 x 62718 2 x 62719 4 x 63218



**Parts Dept**  
Sharon CT 06069

**Tel:** (800) 245-8222

Sales@partsdeptonline.com  
www.partsdeptonline.com

# Maintenance

With only 1 moving part Parts Dept's Interpuls pulsator is designed to be trouble free and easy to maintain. It disassembles with a screwdriver and contains no fluids (as with the DL Hydropuls) so it can be opened any- place, anytime. Follow the routine maintenance below and you will get years of consistent, precise pulsation from your Interpuls pulsator

## Do not lubricate your Interpuls pulsator

**Filter:** At least once a month (more in a dusty environment) clean the plastic filter with a soft brush.

1. Remove pulsator cover
2. Remove plastic filter
3. Clean filter with a soft brush.
4. Place filter back in position.
5. Put cover back on pulsator

**Rubber Parts:** Parts Dept recommends replacing the rubber gaskets in the Interpuls pulsator every 12-18 months. Two parts kits are available: The economy kit and the deluxe kit (see table below for your kit)

	<b>BRK</b>	<b>L-80</b>	<b>LL-90</b>
<b>Deluxe</b>	62712-BRK	62712-ITP	62712-ITP
<b>Economy</b>	962712	962712	962712

**(D) Deluxe Kit includes:**

- 1 x 63466 Base plate gasket
- 2 x 62718 Diaphragm Large
- 1 x 63401 Ratio Slide
- 4 x 63402 Slide Cover
- 2 x 62719 Pilot Valve Diaphragm
- 4 x 63218 Sealing Ring
- 2 x 62798 Felt Filter
- 1 x 63404 Allen Wrench

**(D) Economy Kit includes:**

- 2 x 62718 Diaphragm Large
- 2 x 62719 Pilot Valve Diaphragm
- 4 x 63218 Sealing Ring



**Parts Dept**  
Sharon CT 06069

**Tel:** (800) 245-8222

Sales@partsdeptonline.com  
www.partsdeptonline.com

## Installing your replacement parts kit (Steps 3-11 For Deluxe replacement parts kit)

To install the economy kit follow instructions 1&2

To install deluxe kit follow instructions 3-1

When installing replacement parts we recommend you do so in a clean environment over a piece of white paper so parts can easily be seen if dropped.

**1.** Remove one of the pulsators side covers by removing the screws and pulling the cover off carefully.



**2.** Now you can replace the diaphragms in this side of the pulsator 1 large 1 small and the 2 tiny sealing rings. Take care to make sure the replaced parts are properly seated, replace the cover and install the screws. Repeat this procedure on the other side of the pulsator. This completes the installation of the economy replacement kit.





**Parts Dept**

Sharon CT 06069

**Tel:** (800) 245-8222

Sales@partsdeptonline.com  
www.partsdeptonline.com

## Installing your replacment parts kit

3. Remove both of the pulsators side covers by removing the screws and pulling the covers off carefully.



4. Now you can remove the diaphragms in both side of the pulsator 2 large 2 small and the 4 tiny sealing rings. Once all the diaphragms and sealing rings are removed proceed to step 5.







**Parts Dept**

Sharon CT 06069

**Tel:** (800) 245-8222

[Sales@partsdeptonline.com](mailto:Sales@partsdeptonline.com)

[www.partsdeptonline.com](http://www.partsdeptonline.com)

## Installing your replacement parts kit

5. To access the internal components of the pulsator remove the two screws on the top cover The plastic filter screen is removed by simply pulling up on it (if your pulsator has a felt screen this will also come out with the plastic screen) Clean the plastic filter with a soft brush.



6. To change the slide, take a flat head screwdriver and pry off the slide cover (#66)

**Note: When using the screwdriver take care not to scratch the top of the base plate as this could cause a problem.**

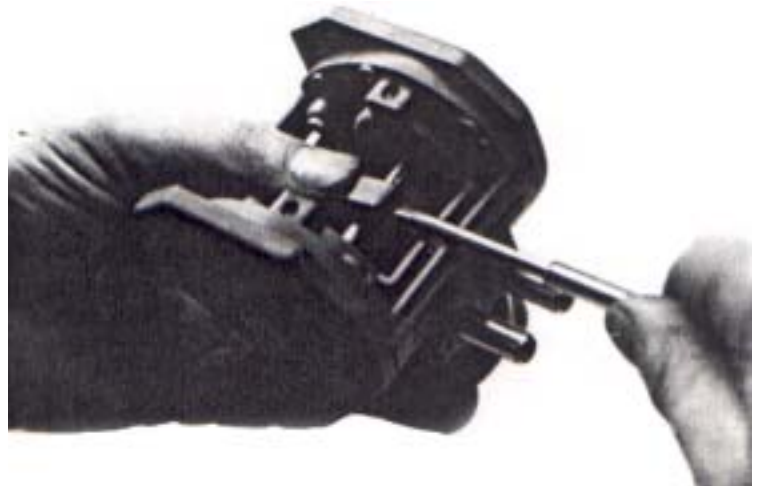



**Parts Dept**

Sharon CT 06069

**Tel:** (800) 245-8222

Sales@partsdeptonline.com  
www.partsdeptonline.com

## Installing your replacement parts kit

7. Now push the slide out from under the steel shaft.



8. Now take a flat head screwdriver and pry off the top of the Pilot Slide (#70) Slide out the Bottom part of the Pilot Slide (#69) from under the steel shaft.





**Parts Dept**  
Sharon CT 06069

**Tel:** (800) 245-8222

Sales@partsdeptonline.com  
www.partsdeptonline.com

## Installing your replacement parts kit

**9.** Now remove the 3 screws holding the Base plate (#57) Remove the baseplate from the pulsator

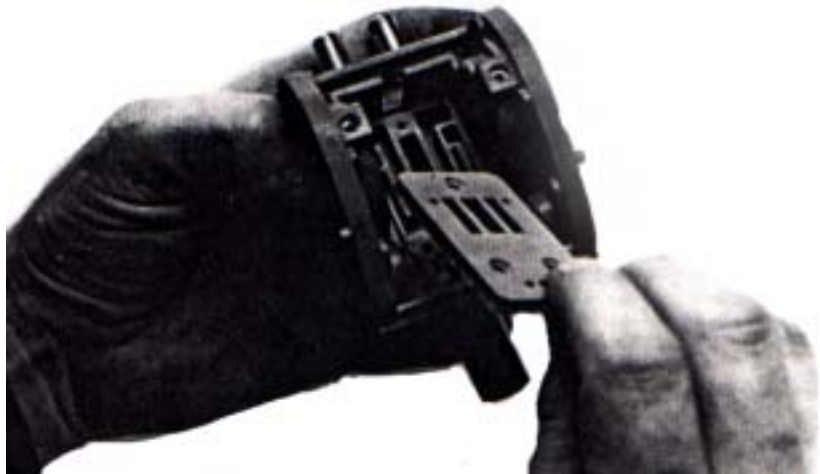

**10.** Separate the Base Plate Gasket (#58) from the Base Plate (#57). Install the new Gasket and Base Plate back into the pulsator.







**Parts Dept**

Sharon CT 06069

**Tel:** (800) 245-8222

Sales@partsdeptonline.com

www.partsdeptonline.com

## Installing your replacement parts kit

### Reassembly

**(Remember do not use oil in the reassembly of the pulsator).**

Since the pulsator is now completely stripped it is a good time to clean the body using warm soapy water and a soft brush, once clean rinse the body in clean warm water. Make sure the pulsator body is completely dry before reassembling the pulsator.

Place the base plate into the body of the pulsator making sure the gasket is correctly positioned so the holes in the gasket and the base plate are aligned, install the base plate screws. Now replace the shafts into the side of the pulsator and install new diaphragms and sealing rings in one side of the pulsator. Now install the side cover and screws. Once one side of the pulsator is rebuilt you can install the diaphragm and sealing rings in the other side and replace the side cover and screws.

Now slide the ratio slide (#65 (this is the big slide)) under the steel shaft closest to the vacuum ports. Note: The ratio slide has 2 raised nubs when installing the slide make sure the short nub is slid under the shaft so it is at the front of the pulsator (by the vacuum ports). If this is put in backwards the pulsator will not function properly.

Now align the ratio slide and the ratio slide cover (#66) and press the slide cover onto the shaft (if there is an arrow on the cover this should point to the vacuum port). Now you can slide the pilot slide bottom (#69) under the rear steel shaft and snap the pilot slide top (#70) onto the shaft. Install the cover and cover screws to complete the pulsator reassembly.

Now install your pulsator into your milking system test the operation of the pulsator (let the pulsator run for several minutes to dry any moisture that may be left in the pulsator from washing).