



Milkplan Tank Instruction Manual



TUV HELLAS



MILKPLAN A.E. ΗΜΕΡΙΔΗΣ - ΜΑΚΡΟΠΟΥΛΟΣ
ΕΞΟΠΛΙΣΜΟΙ ΒΙΟΜΗΧΑΝΙΩΝ ΓΑΛΑΚΤΟΣ & ΚΤΗΝΟΤΡΟΦΙΚΩΝ
ΜΟΝΑΔΩΝ Α.Ε.
3^ο ΧΛΜ. ΛΑΓΚΑΔΑ – ΚΟΛΧΙΚΟΥ, ΘΕΣ/ΝΙΚΗ
Τ.Κ. 57200, Τ.Θ. 212
ΤΗΛ/ΦΑΧ: +30 23940 20400
sales@milkipan.com
www.milkipan.com

MILKPLAN S.A.
IMERIDIS - MAKROPOULOS
DAIRY AND FARMING EQUIPMENT S.A.
3rd KM LAGADAS - KOLHIKO NAT. ROAD GR 572
00, P.O.BOX 212
TEL/FAX: +30 23940 20400
sales@milkipan.com
www.milkipan.com

TABLE OF CONTENTS

| | |
|--|-----------|
| 1. INTRODUCTION | 4 |
| 2. SAFETY RULES AND GENERAL INSTRUCTIONS | 4 |
| 3. PRODUCT INTRODUCTION | 4 |
| 4. LABELING | 5 |
| 5. INSTALLATION INSTRUCTIONS | 6 |
| 5.1 <i>INSTALLATION AND PLACEMENT</i> | 6 |
| 5.2 <i>MILK COOLING TANK LEVELLING</i> | 6 |
| 5.3 <i>ELECTRICAL CONNECTIONS</i> | 6 |
| 6. OPERATION PRINCIPLE | 7 |
| 7. DESCRIPTION | 7 |
| 8. TECHNICAL SPECIFICATIONS | 8 |
| 8.1 <i>GENERAL</i> | 8 |
| 8.2 <i>POWER SPECIFICATIONS</i> | 8 |
| 8.3 <i>MAIN DIMENSIONS</i> | 9 |
| 8.4 <i>CONDITIONS OF MEASUREMENT FOR THE PERFORMANCE OF THE REFRIGERATING UNIT</i> | 9 |
| 9. USING THE TANK | 10 |
| 9.1 <i>COOLING CONTROLLER</i> | 10 |
| 9.2 <i>ADJUSTING THE BASIC PARAMETER VALUES OF THE XR80CX</i> | 10 |
| 10. MILK COOLING TANK MAINTENANCE - CLEANING | 13 |
| 10.1 <i>CLEANING THE TANK</i> | 13 |
| 10.2 <i>CLEANING THE CONDENSER OF REFRIGERATING UNIT</i> | 13 |
| 11. SAFETY MEASURES | 14 |
| 12. MALFUNCTION AND TROUBLESHOOTING | 15 |
| 13. MECHANICAL DRAWINGS (MACHINE PARTS) | 16 |
| 14. ELECTRICAL DATA AND DRAWINGS | 18 |
| 14.1 <i>ELECTRIC LINE OPTIONS TABLE</i> | 18 |
| 14.2 <i>ELECTRICAL DRAWINGS</i> | 19 |
| 15. WARRANTY CERTIFICATE | 20 |
| 16. TECHNICAL SUPPORT & COPYRIGHT | 21 |
| 17. NOTES | 22 |

1. INTRODUCTION

Your new MILKPLAN milk cooling tank is designed and manufactured by experts in cooling and conserving milk. It is constructed using the most modern equipment and technology.

Milk refrigeration is accomplished via a stainless steel straight direct expansion evaporator plate, operated in an economical way and for maximum performance.



The materials used for the construction of the milk cooling tank are of the highest quality in the European Trade Market and guarantee a long life and reliable operation.

The controller is an Italian Dixell type with an error of less than 1%.

The agitator motor is made in France by Sirem and its power is 90W/230V/30 rpm (in types of 50 ~ 1200 lit).

The closed type condensing unit is made by L'Unite Hermetique, a trusted name in the European compressor market.

The base of the milk cooling tank has been designed for safe operation and easy maintenance. The refrigerating unit and the control panel are well protected from external environmental conditions and from small animals and rodents that could enter the refrigerating unit and cause damage.

2. SAFETY RULES AND GENERAL INSTRUCTIONS

During the design and construction of this machine everything has been done to make your job more efficient and secure. However, caution is of great importance. Prevention is better than regulation.

This machine is designed and constructed according to the Annex V directive 98/37 EU and the EN 292-1, EN 292-2, EN 294, EN 349, EN 418, EN 1672-1, EN 1672-2, EN 60204-1 standards.



The exclamation point within an equilateral triangle is intended to alert the user of the presence of important operation and maintenance (service) instructions in this manual. Upon seeing you are highly advised to pay attention to the warning and be careful of any accidents.

After this symbol an instruction follows.

3. PRODUCT INTRODUCTION



ATTENTION! This manual is an integral part of the milk cooling tank and must be kept nearby in a safe place. This should be made known to all users. Do not expose this manual to rain or moisture.

Read this manual regardless of your previous experience. A few moments of careful reading will save time and will prevent many problems. Carefully read the instructions before the start-up of the machine, normal use, maintenance or other functions on the machine, paying close attention to the following orders and warnings.



Place warning stickers on the machine and replace immediately if they have been lost or are not readable.



In order to prevent or reduce risk of accident, the machine should only be operated by adequately trained and responsible staff. Untrained users should never operate the machine.

4. LABELING

The manufacturer's label should be visible at all times as it contains essential information about the manufacturer (address, phone number, fax) and information for the proper installation of the machine (the model, serial number, year of manufacture, refrigeration capacity in Watt, electrical power in Watt, voltage, refrigerant type and quantity) and the CE mark.



WARNING LABELS

The warning labels are to inform the operator of the machine or the equipment and about the remaining risks despite all the measures adopted.



Due to the nature of the tank contents, strict hygiene rules apply. The following labels should be placed where all employees can see them.



The inscriptions (warning labels) should be affixed in a visible, easily legible and non-removable spot on the machine or on to a data plate attached to the machine in such a way that it cannot be removed or become illegible during the lifetime of the machine in the normal working environment.



Keep labels clean and replace them immediately when they become detached or damaged.

5. INSTALLATION INSTRUCTIONS

5.1 INSTALLATION AND PLACEMENT

The milk cooling tank can be installed indoors or outdoors. It is very important for the milk cooling tank to be installed in a **well-ventilated place with a water supply**.

If the tank is to be installed indoors, make sure that the location has sufficient ventilation. Place the tank such that its condenser lies near an opening in order to allow waste heat to be efficiently discarded.

If the tank is to be installed outdoors, it must be placed under a roof so that it cannot be affected by weather conditions (rain, snow, etc).

It is also suggested to place the milk cooling tank on a flat concrete surface. Placing the tank on a flexible or deformable surface can result in inaccurate measurements.

5.2 MILK COOLING TANK LEVELLING

Level the milk cooling tank using a hand spirit level. Open the lid of the tank and place the spirit level on the extremity of the edge of the tank, as shown in the picture below.

Adjust the footings at the base of the tank until it is successfully leveled in both axes.

It is very important to precisely level the tank so that the volume measurements can be accurate



5.3 ELECTRICAL CONNECTIONS

An authorized electrician must complete or verify the electrical installation before placement of the milk cooling tank.

Tanks can be supplied with a variety of voltage and phase specifications. North American tanks are usually designed to operate on single phase, 120 Volt, 60 Hz power. Other voltages and phases are available. Each tank is equipped with a label indicating the proper voltage, current, frequency, and phase requirements.

The cables must be in sized proportion with the electrical power of the milk cooling tank. See table 1 of the appendix in order to choose the type of the cable.

The cable must be straight, without coils (twisted extensions of electrical cable, etc.).

The milk cooling tank power must be supplied from a separate electrical line that is protected with a fuse or circuit breaker for electric motors at the electrical panel.

Powering two milk cooling tanks from one fuse is forbidden.



The electrical connections of the milk cooling tanks of over or equal to 500 liters capacity must be inside the electrical panel, and the electrical line must be connected to an industrial type socket.



ATTENTION! For your protection, the milk cooling tank must be provided with a grounded protective conductor of suitable capacity to ensure the proper grounding of the tank.

After you have performed the electrical connection, measure the voltage loss in the cable by using a voltmeter. While the milk cooling tank is operating, the voltage loss must not be greater than 3% of the electrical circuit. This measurement should be performed while the compressor is operating.



Excessive voltage loss at the feeding cable can cause serious damage to the refrigerating mechanism, and is not covered by the guarantee.

NOTE: Wrong connections at the terminal blocks or the socket plugging can also cause excessive voltage loss.

6. OPERATION PRINCIPLE

The milk cooling tank is especially designed and constructed for the refrigeration and conservation of milk, and to maintain high product quality. Refrigeration must occur immediately after collection to minimize the possibility of spoilage of the milk.

The tank cools the milk by using a refrigeration unit. Homogenous refrigeration is achieved by an agitation paddle, which is rotated by an electrical motor and mechanical reducer. The insulated walls of the milk cooling tank help keep the temperature stable by reducing thermal loss.

7. DESCRIPTION

The milk tank vessel is made of stainless steel 18/10 AISI 304. The vessel consists of two walls. Between them there is environmentally friendly polyurethane foam insulation, which is inserted under controlled infusion. The agitation motor mechanism is mounted to the tank lid and directly connected with the stirring paddle. The paddle is constructed of stainless steel and has two shaped ribs at both its diametrical sides. This shape has been chosen for better and more equalized stirring of the product. A dipstick and a calibration chart are located inside the tank.

The agitator motor and the control panel/controller are located on the milk cooling tank lid. This controller is used as a thermostat, thermometer and a stirring state controller. The milk inlet of a $\varnothing 175$ diameter is placed on the lid, too. A handle is placed on the front of the cover, and is used for opening the lid.

The milk outlet valve (DN50, $\varnothing 52$) is located at the bottom of the tank (models IC 100-300LT). The tank base is made of stainless steel and can be completely dismantled. It consists of the upper and the bottom cover, four adjustable legs, four footing-bases and lateral covers. This has been designed for safe operation, easy maintenance, and full protection from various weather conditions and the entrance of small animals and rodents in the refrigerating unit. This protection is achieved by four stainless steel covers placed at the four sides of the base. These covers are perforated so that the heat produced by the condenser and the compressor can be easily emitted. The perforation holes have dimensions that prevent the entrance of small animals and rodents into the refrigerating unit. In models IC 400-2000LT the refrigerating unit is placed adjacent to the tank, also protected by perforated stainless steel covers.

The stainless steel tank cover has an adjustable, gravity-activated safety switch to interrupt the agitator motor operation when the cover is opened. When the cover is closed, the stirring operation is re-enabled.

8. TECHNICAL SPECIFICATIONS

8.1 GENERAL

CONSTRUCTION: Stainless steel 18/10, DIN 1.4301 (AISI 304) for inner and outer tank vessel.

TANK TYPE: Vertical type cylindrical tank, free standing, smooth inner sides, rounded angles, perfectly polished welding, adjustable legs for uneven floors. Direct expansion bottom designed to ensure total drain of tank. The design of evaporator plates prevents milk freezing even at low milk volumes. Crash test at 60BAR. Function pressure: 30BAR. Fine insulation precisely controlled infusion of high – density environment friendly polyurethane foam. 30rpm (90W) single-phase agitator motor for IC 50 – 1200liters, 30rpm (120W) single-phase agitator motor for IC 1500 – 2000liters , stainless steel lid without any screws inside and one-piece agitator (without joints). Automatic stop of the agitation motor in case the lid opens. Milk inlet Ø180mm and stainless steel cover. Elevated parts (opening handle, stirring motor and electrical control panel) for easy cleaning. Milk outlet and milk cooling tank evaporator plate inclination according to the international standards (ISO 5708). Stainless steel springs for easy opening and closing of the milk cooling tank lid (for IC 200 – 2500 liters). Stainless steel dipstick and standard calibration chart. IP55 panel for electric instrument (Applicable Standard: EN 60529/91, Applicable directives: LVT 73/23/EEC). Stainless steel 2" sanitary fitting to accommodate user-specified output valve. Perforated stainless steel condensing unit cover with removable sides for easy maintenance and for the condensing unit ventilation – protection (Patent No. : 1004080) for IC 50lt-1000lt.

CONDENSING UNIT: Close type condensing unit compressor by L'Unite Hermetique, coolant type R404A (full ecological).

A solenoid valve, high pressure switch, low pressure switch, high pressure switch for the second run regulation (Models IC 1000-2500lt) on the refrigerating circuit) protect the condensing unit and improve its performance.

INSULATION TYPE: INTERVOL RFN-24. Two components polyurethane rigid foam system. Blowing agent used is HCFC-141b (CFC – free system). Thickness: 45mm. Density: 40kg/m³ (DIN53420). Compressive strength: 20kPa (DIN53421). Thermal conductivity, 24°C: 0.023 W/m °K (DIN18164).

PANEL FOR ELECTRIC INSTRUMENT: PROTECTION CLASS: IP 55 class-standard (Applicable Standard: EN 60529/91, Applicable directives: LVT 73/23/EEC). TYPE: Tank mounted.

MILK CONTROLLER - THERMOSTAT: OPERATING TEMPERATURE: +0 ÷ +60°C. STORAGE TEMPERATURE: -30 ÷ +85°C. POWER SUPPLY: 230V – 50Hz ± 10%. POWER ABSORPTION: 3VA max. MANUFACTURER: DIXELL SRL, ITALY. FUNCTION: When the compressor reaches the set point, it stops its function and the auto agitation of milk begins for 15minutes pause, 3 minutes agitation and so on until the milk temperature SET+ Hy when the compressor starts again. In case of probe failure , the output is according to parameter "CON" - Compressor ON time with faulty probe (range: 0 ÷ 255min, val.15min) and "COF" " - Compressor OFF time with faulty probe (range: 0 ÷ 255min, val.30min). Note: All of the milk controller parameters are adjustable.

DIPSTICK: High precision stainless steel dipstick (AISI 304) for easy and direct volume reading in mm.

8.2 POWER SPECIFICATIONS

(Note: Other tank sizes, voltages and capacities are available.)

| Milk Cooling tank type | Maximum capacity Liters | Weight Kg | Fan cooled condensing unit type | Voltage | Refrigerant type | Refrigeration capacity Watt | Maximum Power Rate | Run current | Maximum current | Number of milking |
|------------------------|-------------------------|-----------|---------------------------------|------------------|------------------|-----------------------------|--------------------|-------------|-----------------|-------------------|
| IC 50 | 60 | 40 | AEZ9440Z L'Unite | 115V 60Hz, 1~ | R 404A | 743W 3/8Hp | 636W | 5.4A | 3,00A | 2 |
| IC 100 | 125 | 60 | CAE4450Z L'Unite | 115V 60Hz, 1~ | R 404A | 927W 3/7Hp | 756W | 8.3A | 4.19A | 2 |
| IC 200 | 230 | 100 | CAJ9510Z L'Unite | 115V 60Hz, 1~ | R 404A | 1972W 1Hp | 1299W | 13.7A | 7.10A | 2 |
| IC 300 | 332 | 110 | CAJ9513Z L'Unite | 115V 60Hz, 1~ | R 404A | 2485W 1_1/8Hp | 1683W | 16.1A | 10.10A | 2 |

8.3 MAIN DIMENSIONS

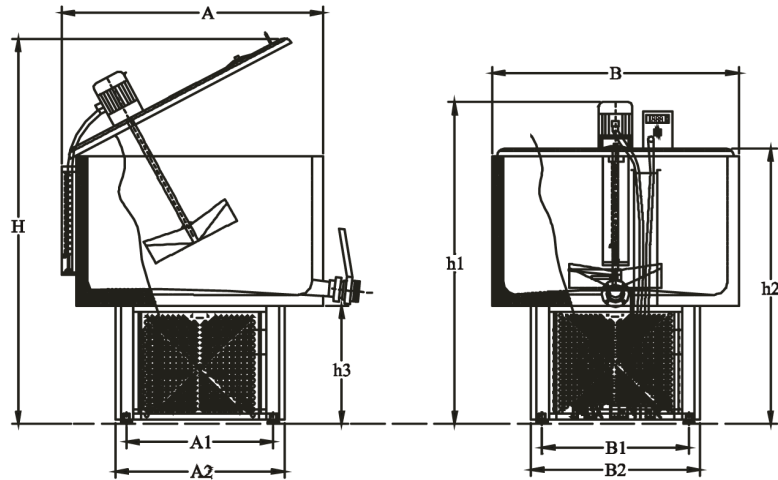

| Milk Cooling tank | A | A1 | A2 | B | B1 | B2 | H | h1 | h2 | h3 |
|-------------------|------|-----|-----|-----|-----|-----|------|------|------|-----|
| IC 50 | 560 | 280 | 365 | 520 | 280 | 365 | 1350 | 1050 | 820 | 440 |
| IC 100 | 720 | 330 | 400 | 680 | 410 | 490 | 1660 | 1190 | 980 | 420 |
| IC 200 | 1000 | 530 | 610 | 880 | 530 | 610 | 1760 | 1220 | 990 | 420 |
| IC 300 | 1100 | 530 | 600 | 980 | 530 | 610 | 1900 | 1250 | 1030 | 420 |

8.4 REFRIGERATING UNIT PERFORMANCE MEASUREMENT CONDITIONS

- Ambient temperature: +32 °C
- Evaporator outlet and emission gas superheated: 32K
- Condensing temperature is +55 °C
- Evaporating temperature: 0 °C
- Temperature of refrigerant at condenser outlet is sub cooled within the condensing limits of the unit
- The technical characteristics of the refrigerating units are mentioned in the manufacturers catalogues

9. USING THE TANK

9.1 COOLING CONTROLLER

Milkplan open type tanks employ specialized Dixell XR80CX controllers to control milk cooling and preservation processes.



Main characteristics:

- User friendly interface
- Accurate control
- Manual start of agitation
- All the parameters are fully configurable
- Current temperature always displayed on the screen
- Indication LED for cooling and agitation operation

DIXELL XR80CX CONTROLLER

A DIXELL XR80CX controller operates and controls the refrigerating milk tank.

This flexible controller permits automatic operation of the tank with a single ON/OFF switch.

The stirring (agitator) operation is mechanically regulated and requires no user action in order to operate it. The agitator operates at all times when the refrigerating compressor is active. When refrigeration is completed, the compressor stops and the agitator operates at cycles of 3 minutes rotation and 15 minutes pause. (These intervals are adjustable).

Always remember that you should:

Set the refrigerating milk tank in operation mode **as soon as the agitation paddle is covered with milk**. Do not turn the tank off as long as it contains milk.

Turn the milk cooling tank off when it does not contain milk.

Avoid opening the tank lid as long as it is in operation because the agitator stops and there is a risk of rapid ice formation.

To take a milk sample while the agitator is in the 15 minutes non-operating interval, push and hold the  button-key to make it operate. This will allow you to take a homogeneous sample.

During winter and if the temperature falls under 4°C, the milk cooling tank may not start immediately. It is necessary to put hot milk in the tank and wait a few minutes until the refrigerating unit starts to operate.

9.2 ADJUSTING THE BASIC PARAMETER VALUES OF THE XR80CX

After the milk cooling tank is switched on, a dashed line is displayed on the controller's screen. Next, the temperature of the room where the milk cooling tank is installed is displayed.

1. First press the SET key-button together with the (▼) key for at least 7seconds
2. Led **Hy** is displayed.
3. Repeat step 2 pressing both keys for 7 sec. Led **Pr 2** will be displayed. Release the keys and **Hy** is displayed.
4. Press the SET key until the **Hy** temperature (2.0°C) is displayed.
5. By pressing the SET key again the **LS** is displayed.
6. Press the SET key, and then by pressing the (▲▼) keys you can set the minimum temperature.
7. **The temperature is already set to 1.0°C**
8. By pressing the SET key, the display blinks three times meaning that the temperature you set has been stored.
9. After this, the led **US** is displayed. Press the SET key, and then by pressing the (▲▼) keys you can set the maximum temperature. **The maximum temperature is already set to 5.0°C.**
10. By pressing the SET key, the display blinks three times meaning that the temperature you set has been stored.
11. Immediately after, the led **Ot** is displayed which calibrate the thermostat probe. Push the SET key once, and by pressing (▲▼) set the desirable temperature. Press the SET key again and the display blinks three times meaning that the temperature set has been stored. **The value of parameter is set to -0,5°C**

Soft start function

If at start up, or during the regulation process, the input signal value is higher than the "SrS+Hy", the controller starts the regulation considering as target temperature the parameter SrS. When the temperature reaches the SrS value the compressor stops. Then after the time set in parameter Srt, the controller starts the regulation based on the standard SET POINT.

How to reset the soft start parameters

In order to reset the values of the soft start parameters you have to follow the 5 first steps of the chapter "checking the basic parameters values ". Afterwards you have to press and release the SET key until you reach the parameter Srt. The value of this parameter is 0min. and if you wish to change it you have to press the arrows. After the calibrating of the parameter press the SET key, the display blinks 3 times which means that the value has been stored. After this the controller passes automatically to the parameter SrS which adjusts the temporary stop of the compressor. The value of this parameter is 15°C and if wish to change it you have to press the arrows. After calibrating you should press the SET key to store the new value.

To exit press the SET + ▲ or wait 15s without pressing a key.

How to see the Set Point

1. Push and immediately release the SET key: The display will show the Set point value.
2. Push and immediately release the SET key or wait for 3 seconds to display the probe value again.

How to change the Set Point

1. Push the SET key for more than 3 seconds to change the point Set value;
2. The value of the set point will be the displayed and the * LED starts blinking.
3. To change the set value push ▲ or ▼ arrows.
4. To memorise the new set point value push the SET key again or wait for 15seconds.

How to start a manual agitation cycle

1. Push the Up (▲) key for more than 3 seconds and the manual agitation cycle will start.

How to see the min temperature

1. Press and release the ▼ key.
2. The Lo message will be displayed followed by the minimum temperature recorded.
3. By pressing the ▼ key again or by waiting for 5seconds the normal display will be restored.

How to see the max temperature

1. Press and release the ▲ key.
2. The Hi message will be displayed followed by the maximum temperature recorded.
3. By pressing the ▲ key again or by waiting 5seconds the normal display will be restored.

How to change a parameter value

1. Enter the programming mode by pressing the SET and ▼ key for 7s (Ⓞ and * start blinking)
2. Select the required parameter.
3. Press the SET key to display its value (* LED starts blinking)
4. Use (▲▼) to change its value
5. Press SET to store the new value and move to the following parameter. (To exit press the SET + ▲ or wait 15s without pressing a key.)

How to lock the keyboard

1. Press and hold for more than 3seconds the (▲▼) keys
2. The POF message will be displayed and the keyboard will be locked. At this point it will be possible to see only the set point or the MAX or MIN temperature stored.
3. If a key is pressed more than 3seconds the POF message will be displayed.

To unlock the keyboard

1. Keep pressed together for more than 3s the ▲▼ keys.

Meaning of LED

*ON: Compressor enabled.

*Flashing: - Programming phase (flashing with Ⓞ) - Anti-short cycle delay enabled

Ⓞ ON: Agitator enabled

Ⓞ Flashing: Programming phase (flashing with*)

ALARM SIGNALS

EE: The instrument is provided with an internal check verifying memory integrity. The ALARM "EE" flashes when a failure in the internal memory is detected. In such case call the service.

P1: Probe alarm -P1- starts several seconds after the fault in the related probe. It automatically stops several seconds after the probe restarts normal operation. Check connections before replacing the probe. In case of fault in the thermostat probe, the starting and the stopping of the compressor are regulated through parameters **Con** & **COF**.

HA: Maximum temperature alarm automatically stops as soon as the thermostat temperatures returns to normal and when defrosting stops.

LA: Minimum temperature alarm automatically stops as soon as the thermostat temperature returns to normal and when defrosting stops.

DEFAULT SETTING VALUES

| Label | Name | Range | Value |
|------------|---|--|---------------------|
| Set | <i>Set point</i> | LS-US | 4,0 |
| Hy | <i>Differential</i> | 0,1-25,5 ^{°C} / 1-255 ^{°F} | 2,0 |
| LS | <i>Minimum set point</i> | -50 ^{°C} – SET 58 ^{°F} - SET | 1.0 ^{°C} |
| US | <i>Maximum set point</i> | SET – 150 ^{°C} SET – 302 ^{°C} | 5.0 ^{°C} |
| Ot | <i>Thermostat probe calibration</i> | -12 ^{°C} – +12 ^{°C} -120 - +120 ^{°C} | - 0,5 ^{°C} |
| OdS | <i>Outputs delay at start up</i> | 0 – 255 min | 0 |
| AC | <i>Anti-short cycle delay</i> | 0 – 50 min | 1 |
| Con | <i>Compressor On time with faulty probe</i> | 0 – 255 min | 15 |
| COF | <i>Compressor OFF time with faulty probe</i> | 0 – 255 min | 30 |
| CF | <i>Temperature measurement units</i> | °C - °F | °C |
| rES | <i>Resolution</i> | In : dE | dE |
| AgC | <i>Agitator configuration</i> | EL = with compressor In = independent | EL |
| tIC | <i>Resolution for the Agt parameter</i> | nP = minutes Pb = seconds | nP |
| IAg | <i>Interval between agitation cycle</i> | 1 – 120 min | 15 |
| Agt | <i>Length for agitation cycle</i> | 0 – 255 min | 3 |
| APO | <i>First agitation cycle after start up</i> | n= immediately y= after IAg | Y |
| ALc | <i>Temperature alarms configuration</i> | rE – Ab | Ab |
| ALU | <i>Maximum temperature alarm</i> | ALL-150 ^{°C} ALL-302 ^{°F} | 100 |
| ALL | <i>Minimum temperature alarm</i> | -50.0 ^{°C} -ALU -58 ^{°F} -ALU | -50 |
| ALd | <i>Temperature alarm delay</i> | 0 – 255 min | 15 |
| dAo | <i>Delay of temperature alarm at start up</i> | 0 – 23 h & 50 min | 1,3 |
| PbC | <i>Probe selection</i> | Ptc-ntc | ntc |
| Srt | <i>Initial regulation time</i> | 0 – 59min | 0 |
| SrS | <i>Initial regulation Set point</i> | -55,0 ^{°C} – 150,0 ^{°C} | 15 |
| rEL | <i>Software release</i> | - | 3,0 |
| Ptb | <i>Map code</i> | - | 2 |

*Hidden parameters

10. MILK COOLING TANK MAINTENANCE - CLEANING

The milk cooling tank has special maintenance and cleaning requirements. The machine is used for the refrigerating and the conservation of milk, so it requires **daily** and efficient cleaning. The cleaning of the inside of the tank, which is in contact with the milk, as well as the external surface of the milk cooling tank, should be performed with hot water and a suitable smooth brush (picture 5).



Before every cleaning or maintenance job, ensure that the milk cooling tank has been properly disconnected from electricity.

Cleaning and maintenance are performed after the machine has been unplugged from electricity.

Clean the external and internal surfaces of the tank daily.

10.1 CLEANING THE TANK

Empty the tank and rinse it with cold water in order to remove remaining milk residue. Then, clean the tank carefully with hot water at about 45°C, using detergents only used for foods.

Rinse the interior of the tank out with plenty of cold water and scrub it with a brush suitable for commissary until it is thoroughly cleaned.



After cleaning the tank, dry it thoroughly by using an absorbent paper towel or special cloth that does not leave thrum, which can cause infection or electric shock.

Clean the control panel by using a wet piece of cloth after disconnecting the machine from electricity.

10.2 CLEANING THE REFRIGERATING UNIT CONDENSER

It is absolutely necessary to periodically clean the condenser of the refrigerating unit, in order to assure long-lasting and reliable operation of the milk cooling tank.

Clean the condenser by first unscrewing the screws that attach the lateral cover at the side of the condenser, and removing the lateral cover. You may then clean the condenser by using pressurized air. You can also clean the condenser by carefully using a brush in order to remove dust and other debris from its surface.

DO NOT USE WATER TO CLEAN THE CONDENSER.



11. SAFETY MEASURES

The milk cooling tank is fitted with safeguards at all its moving parts. Access to the interior of the electric panel requires the use of a screwdriver and is in accordance with the requirements for the safeguards of the directive 98/37/EK

The electric parts of the installation are adequately covered in order to be safe in use (ex: wires).

The surface of the milk cooling tank is smooth, continuous and formed so as to reduce milk entrapment in small cracks and decrease bacteria contamination which can cause infection in the milk. Furthermore, the surfaces are cleanable and easy to disinfect where needed.

Inaccessible places are constructed in such a way so as to be easily cleanable.

The bearings are fitted at the out-of-food area. Their lubrication is performed by the use of special lubricant suitable for food.



Before maintenance or cleaning, make sure that the milk cooling tank has been disconnected from electricity.



Always remember: Proper cleaning and maintenance of the machine makes your job more productive and safe.

Do not remove the signs from the machine.



After your work is finished, cover the machine with a dustsheet in order to prevent dust from collecting on the tank or falling into an opened tank. Place all the protective covers in place.

12. MALFUNCTION AND TROUBLESHOOTING

| MALFUNCTION | POSSIBLE CAUSE | TROUBLESHOOTING |
|---|---|---|
| The device does not operate at all. There is no voltage at the control panel. | No voltage. | <p>Check if the operation button is at ON position (lit LED).</p> <p>Check if there is voltage at the electric line that feeds the milk cooling tank.</p> <p>Check the fuse of the electric line that feeds the milk cooling tank.</p> <p>Check the electric connections at the electric panel and the socket of the tank.</p> <p>Check the connection terminal blocks.</p> <p>If the problem is not solved, contact authorized services.</p> |
| The stirrer and the condenser ventilator work but the refrigerating compressor does not work. | The thermal fuse stopped operation probably due to loss of voltage or compressor failure. | <p>Wait for 2 minutes until the thermal fuse permits operation again.</p> <p>If the problem occurs again, check the circuit voltage and the voltage loss at the unit.</p> <p>If there is sufficient voltage and the problem is not solved, contact authorized services.</p> |
| In case any thermal protection fails, you should open the control panel and fix it (IC 400 – 2500). | | |

For any other problem, contact the service department of the company.

13. MECHANICAL DRAWINGS (MACHINE PARTS)

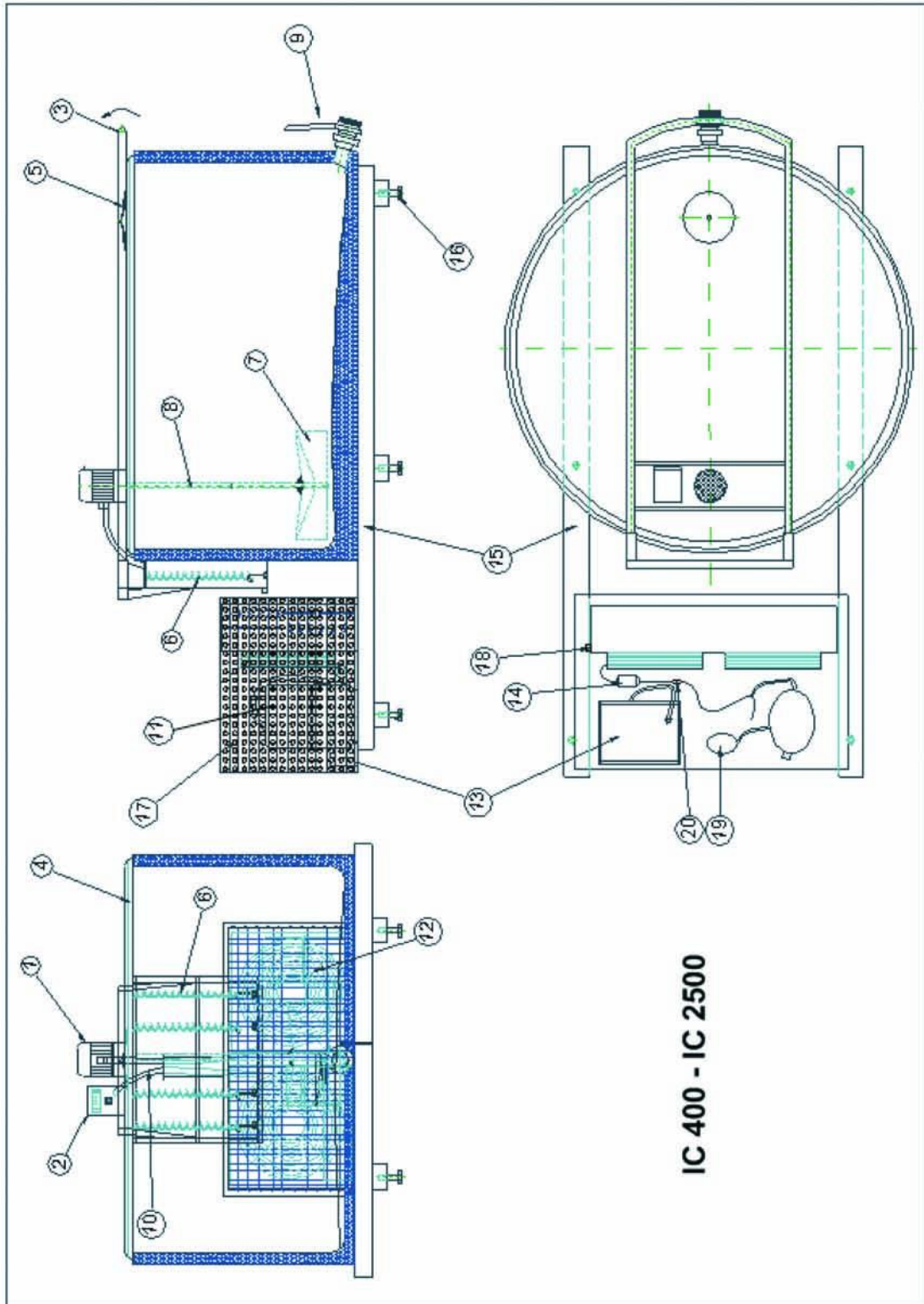

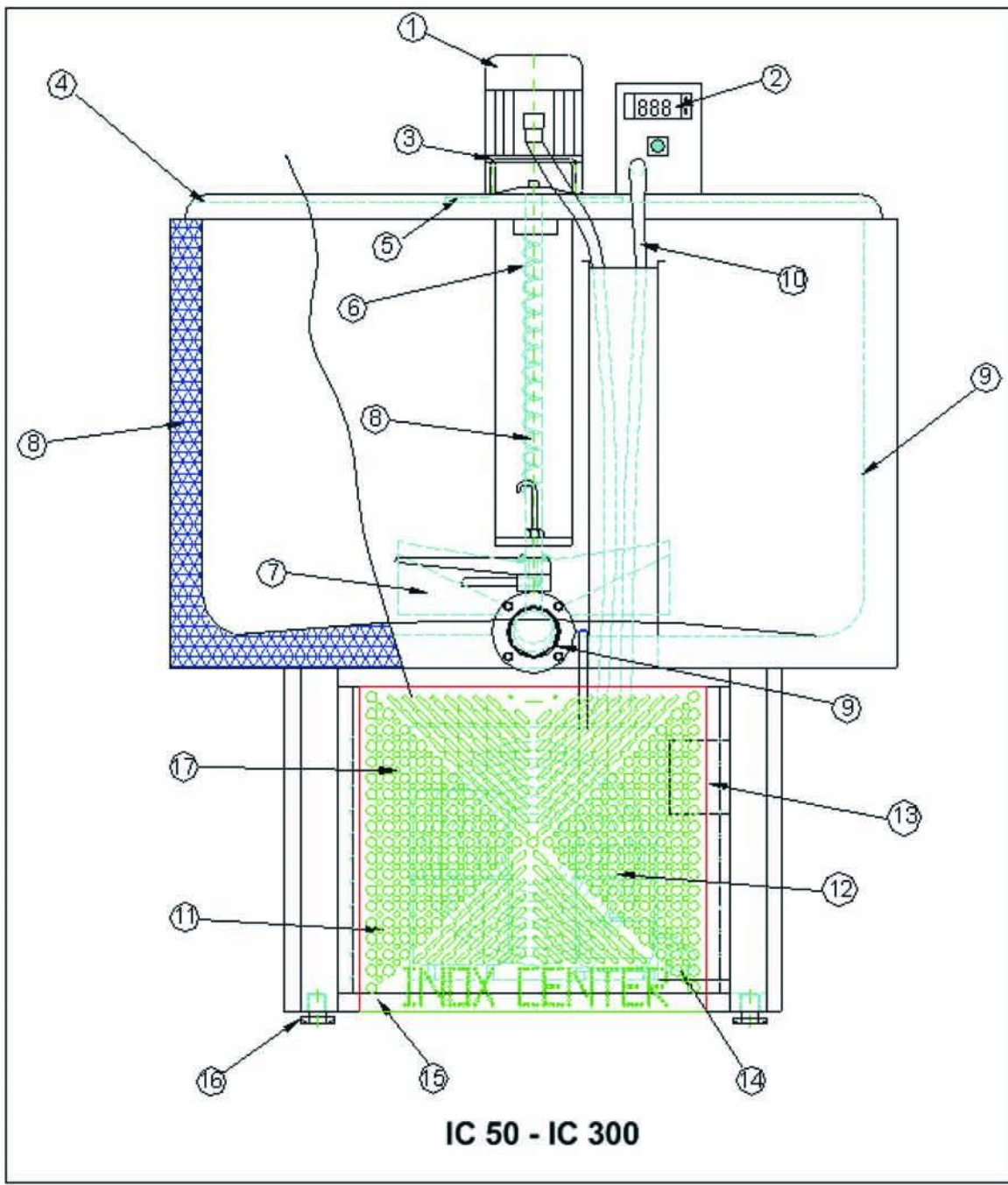

IC 50 - IC 300

14. ELECTRICAL DATA AND DRAWINGS

14.1 ELECTRIC LINE OPTIONS TABLE

2 MILKING

| Type | Power | Fuse | Electrical line length | Cross sectional area |
|--------|-------|------|------------------------|----------------------|
| | W | A | m | mm ² |
| IC 100 | 756W | 10 K | 25 | 1,5 |
| | | | 50 | 1,5 |
| | | | 75 | 1,5 |
| | | | 100 | 1,5 |
| | | | 125 | 2,5 |
| | | | 150 | 2,5 |
| IC 200 | 1235W | 10 K | 25 | 1,5 |
| | | | 50 | 1,5 |
| | | | 75 | 1,5 |
| | | | 100 | 2,5 |
| | | | 125 | 2,5 |
| | | | 150 | 4 |
| IC 300 | 1443W | 10 K | 25 | 1,5 |
| | | | 50 | 1,5 |
| | | | 75 | 2,5 |
| | | | 100 | 4 |
| | | | 125 | 4 |
| | | | 150 | 6 |
| IC 400 | 2507W | 16K | 25 | 2,5 |
| | | | 50 | 2,5 |
| | | | 75 | 2,5 |
| | | | 100 | 4 |
| | | | 125 | 4 |
| | | | 150 | 4 |
| IC 500 | 2507W | 16 K | 25 | 2,5 |
| | | | 50 | 2,5 |
| | | | 75 | 2,5 |
| | | | 100 | 4 |
| | | | 125 | 4 |
| | | | 150 | 4 |
| IC 650 | 2764W | 16K | 25 | 2,5 |
| | | | 50 | 2,5 |
| | | | 75 | 2,5 |
| | | | 100 | 4 |
| | | | 125 | 4 |
| | | | 150 | 6 |

| Type | Power | Fuse | Electrical line length | Cross sectional area |
|---------|-------|--------|------------------------|----------------------|
| | W | A | m | mm ² |
| IC 800 | 3563W | 20 K | 25 | 2,5 |
| | | | 50 | 2,5 |
| | | 25 K | 75 | 4 |
| | | | 100 | 4 |
| | | | 125 | 6 |
| | | | 150 | 6 |
| IC 1000 | 4703W | 25 K | 25 | 2,5 |
| | | | 50 | 4 |
| | | 30 K | 75 | 4 |
| | | | 100 | 6 |
| | | | 125 | 6 |
| | | | 150 | 10 |
| IC 1200 | 4588 | 3x16 K | 25 | 5x2,5 |
| | | | 50 | 5x4 |
| | | 3x20 K | 75 | 5x4 |
| | | | 100 | 5x4 |
| | | | 125 | 5x6 |
| | | | 150 | 5x6 |
| IC 1500 | 5344W | 3x16 K | 25 | 5x2,5 |
| | | | 50 | 5x4 |
| | | 3x20 K | 75 | 5x4 |
| | | | 100 | 5x4 |
| | | | 125 | 5x6 |
| | | | 150 | 5x6 |
| IC 2000 | 7858W | 3x20 K | 25 | 5x2,5 |
| | | | 50 | 5x4 |
| | | 3x25 K | 75 | 5x4 |
| | | | 100 | 5x4 |
| | | | 125 | 5x6 |
| | | | 150 | 5x6 |

14.2 ELECTRICAL DRAWINGS

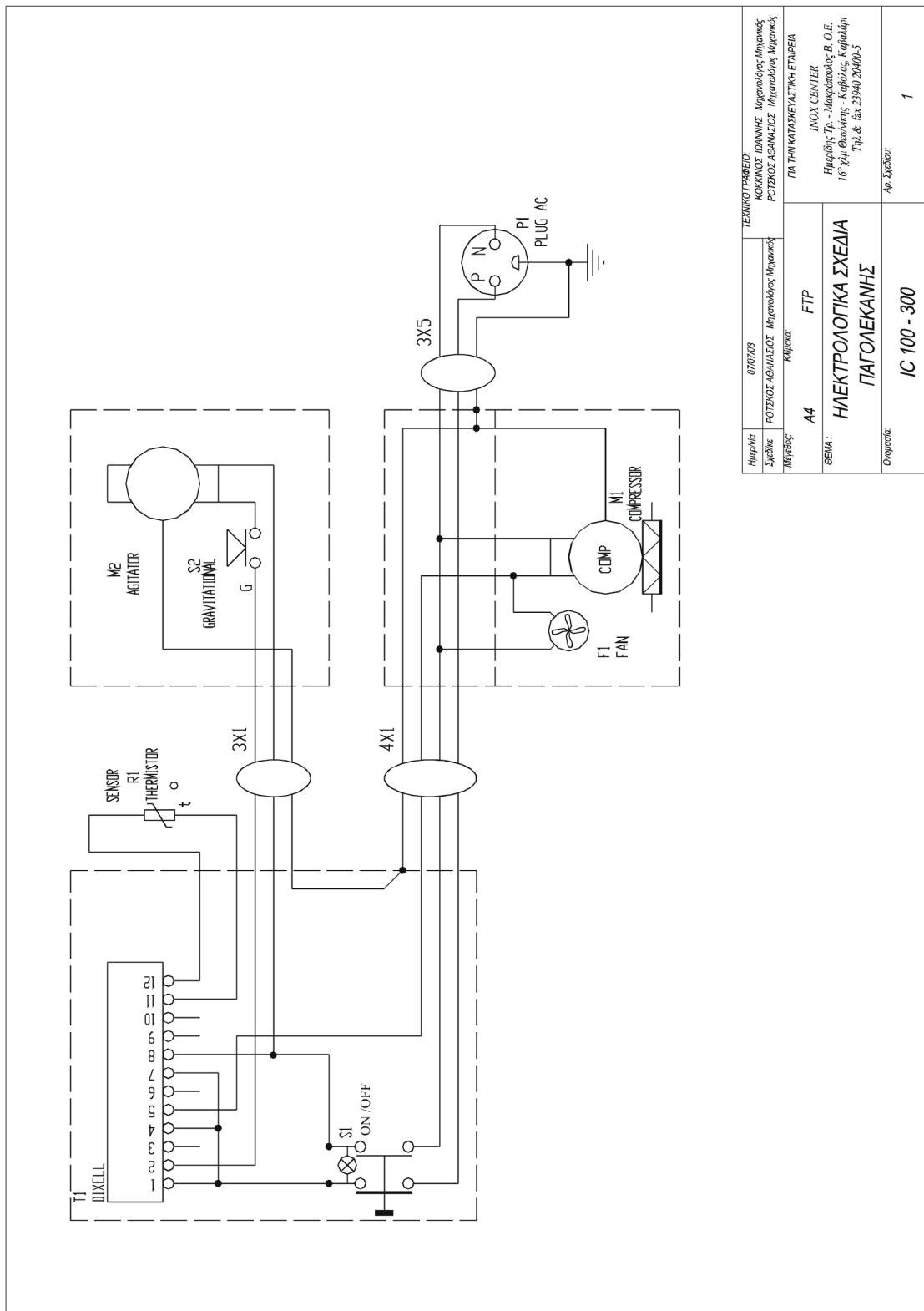

| | | |
|------------------------------|---|--|
| Ημερίδα Σχέσης Μελέτης | 07/07/03 ΦΩΤΣΚΟΣ ΑΘΑΝΑΣΙΟΣ Μηχανολόγος Μηχανικός | ΤΕΧΝΙΚΟ ΓΡΑΦΕΙΟ ΚΟΚΚΙΝΟΣ ΙΩΑΝΝΗΣ Μηχανολόγος Μηχανικός ΡΟΤΣΚΟΣ ΑΘΑΝΑΣΙΟΣ Μηχανολόγος Μηχανικός |
| Μέγεθος | A4 | Μήσκας FTP |
| ΒΕΛΙΑ: | INOX CENTER Ημερίδα: Τρ. - Μαυρολάδας, Β. Ο.Ε. 16' Χμ. Θεσσαλονίκης - Καβάλας, Καβάλα Τηλ. & fax 23940 20400-5 | |
| Όνομα: | Αρ. Σχέσης: IC 100 - 300 | |
| | | 1 |

15. WARRANTY CERTIFICATE

Με την παρούσα ο κατασκευαστής εγγυάται την καλή λειτουργία του μηχανήματος που αναφέρεται παρακάτω:

The manufacturer warrants this product as being free of defects in material, design and workmanship:

ΗΜΕΡΙΔΗΣ ΜΑΚΡΟΠΟΥΛΟΣ MILKPLAN A.E.
ΕΞΟΠΛΙΣΜΟΙ ΒΙΟΜΗΧΑΝΙΩΝ ΓΑΛΑΚΤΟΣ &
ΚΤΗΝΟΤΡΟΦΙΚΩΝ ΜΟΝΑΔΩΝ
3ο χλμ. Ε.Ο. Λαγκαδά – Κολχικού
Ελλάδα
Τ.Κ. 57200 Τ.Θ. 212
Τηλ./fax: +30 23940 20400
Α.Φ.Μ. 084205083 – ΔΟΥ Λαγκαδά



IMERIDIS MAKROPOULOS MILKPLAN S.A.
DAIRY AND FARMING EQUIPMENT
3rd Km Lagadas - Kolhiko National Road
Greece
P.C. 57200, P. O. box 212
Tel & Fax: +30 23940 20400
Vat No:EL084205083 – IRS of Lagadas

ΕΓΓΥΗΣΗ Νο. / WARRANTY N°:

Στοιχεία πελάτη / Client data

Επωνυμία / Name:

Διεύθυνση / Address:

Πόλη / City:

Τηλέφωνο / Telephone:

Α.Φ.Μ./ VAT No:

ΔΟΥ / Internal revenue service:

Παραστατικό αγοράς / Receipt of trade:

Ημερομηνία αγοράς / Date of trade:

Λήξη ισχύος εγγύησης / End of warranty:

Τύπος μηχανής / Machine type:

Αριθμός σειράς / Serial number:

Με την αγορά της συσκευής που αναφέρεται στο παραπάνω τιμολόγιο αγοράς, η εταιρία παρέχει εγγύηση καλής λειτουργίας διάρκειας ενός (1) έτους.

The company provides the machine with one-year (1) warranty of good operation.

Η συσκευή έχει ελεγχθεί από το εργοστάσιο κατασκευής, λειτουργεί κανονικά και κατά τους ελέγχους δεν παρουσίασε κανένα πρόβλημα. Η εγγύηση καλύπτει όλα τα μέρη της παγολεκάνης εκτός του συμπιεστή.

The machine has been examined at the manufacturing plant and confirms that it operates normally and does not have any problems. The warranty covers all the parts of the milk cooling tank apart from the compressor.

ΓΙΑ ΤΗΝ / FOR Milkplan
(ο αντιπρόσωπος- σφραγίδα & υπογραφή)
(The authorized dealer-stamp and signature)

Ο ΑΓΟΡΑΣΤΗΣ / THE PURCHASER

Η ΕΓΓΥΗΣΗ ΔΕΝ ΙΣΧΥΕΙ ΟΤΑΝ:

- Η συσκευή έχει ανοιχθεί από μη εξουσιοδοτημένο από την εταιρία μας τεχνικό.
- Η συσκευή παρουσιάζει φθορές που προέρχονται από πτώση κτυπήματα κ.λ.π.
- Η βλάβη έχει προέλθει από πλημμύρα, υπερβολική υγρασία ή πυρκαγιά.
- Η συσκευή παρουσιάζει προβλήματα που προέρχονται από κακή ποιότητα ρεύματος, ελλιπή τάση, κακή ηλεκτρολογική εγκατάσταση.

(Τάση λειτουργίας: 220V ± 3%, 50Hz)

Η συσκευή προσκομίζεται για service στην έδρα της εταιρίας μας με ευθύνη του ιδιοκτήτη, άσχετα με το εάν οι εργασίες καλύπτονται από την εγγύηση ή όχι.

THE WARRANTY IS NOT VALID IF:

- A non-authorized technician has serviced the machine.
- The machine appears damaged from a fall or strikes etc.
- Flood, excessive moistness or fire has caused the damage.
- The machine malfunctions caused by low voltage, wrong electrical installation
(Voltage 220V± 3%, 50Hz).

The machine is brought to the company's service regardless of the warranty's validation.

16. TECHNICAL SUPPORT

For further information for the technical support, contact the MILKPLAN service:

MILKPLAN S.A.
IMERIDIS - MAKROPOULOS
DAIRY AND FARMING EQUIPMENT S.A.
3rd KM LAGADAS - KOLHIKO NAT. ROAD
GR 572 00, P.O.BOX 212
TEL/FAX : +30 23940 20400
sales@milkplan.com
www.milkplan.com

Before you contact our company, find the metal plate that has the serial number of the milk cooling tank and write it down so as to have it when you are asked for it.

MANUAL EDITING COPYRIGHT

This manual is part of the research into the requirements that should be fulfilled according to the following standard: European Safety Regulations for European machines, 98/37/EEC. According to this research, the machine could have the CE mark.

This manual is a part of the **MILK COOLING TANK** and it must be available to anyone who wishes to operate, maintain, repair or control the milk cooling tank function.

Do not expose this manual to water, moisture and dust or to extreme temperatures. Keep it near the machine.

In case of damage or loss, ask for a copy from the manufacturer or the Authorized Service Center.

This manual is published by:



ΗΜΕΡΙΔΗΣ - ΜΑΚΡΟΠΟΥΛΟΣ MILKPLAN A.E.
IMERIDIS - ΜΑΚΡΟΠΟΥΛΟΣ MILKPLAN S.A.

TECHNICAL OFFICE - MECHANICAL STUDIES

IOAN.S.KOKKINOS – ATH. ROTSKOS

Mechanical Engineers / Technical Business Consultants



MACHINE STUDIES
CE CERTIFICATION
ISO SYSTEMS DEVELOPMENT
WORK PERMIT
SAFETY ENGINEERING SERVICES

BOULGARI ST.40, P.C. 54249, THESSALONIKI

TEL +30 2310 320094 & FAX +30 2310 302084

mobile tel 6977 077.022 e-mail: arots@tee.gr, www.rotskos.gr

Copyright © 2012 MILKPLAN