

MilkPlan Bulk Tanks 15 Gallon - 90 Gallon: Dimensions & Specifications

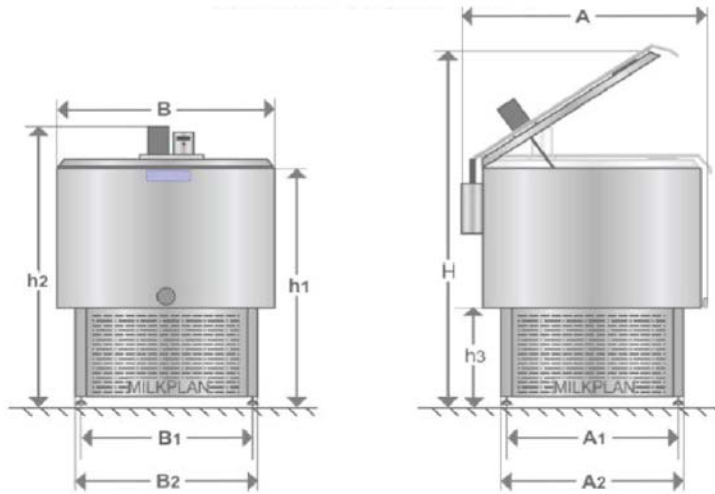

Dimensions in Inches										
Tank Size	A	A ₁	A ₂	B	B ₁	B ₂	H	h ₁	h ₂	h ₃
15-Gallon	22.0	11.0	14.4	20.5	11.0	14.4	53.1	41.3	32.3	17.3
30-Gallon	30.7	13.0	15.7	26.8	16.1	19.7	65.4	46.9	38.6	16.5
60-Gallon	40.6	20.9	24.0	35.0	20.9	24.0	59.8	48.0	39.0	16.5
90-Gallon	44.5	20.9	24.4	39.0	20.9	24.0	66.9	49.2	40.6	16.5

Technical Specifications									
Tank Size	Max Capacity (Gallons)	Weight (lbs)	Voltage	Refrigerant	HP	BTU/hr	Amps	Max Amps	
15-Gallon	114.7	114	110V	R404A	3/8 HP	3072	2.2A	3.0A	
30-Gallon	140.5	158	110V	R404A	1/2 HP	3801	3.76A	4.19A	
60-Gallon	174.1	242	110V	R404A	1 HP	7414	5.2A	7.10A	
90-Gallon	224.5	282	110V	R404A	1 1/4 HP	9513	6.4A	10.10A	

MilkPlan Bulk Tanks 220 Gallon - 330 Gallon: Dimensions & Specifications

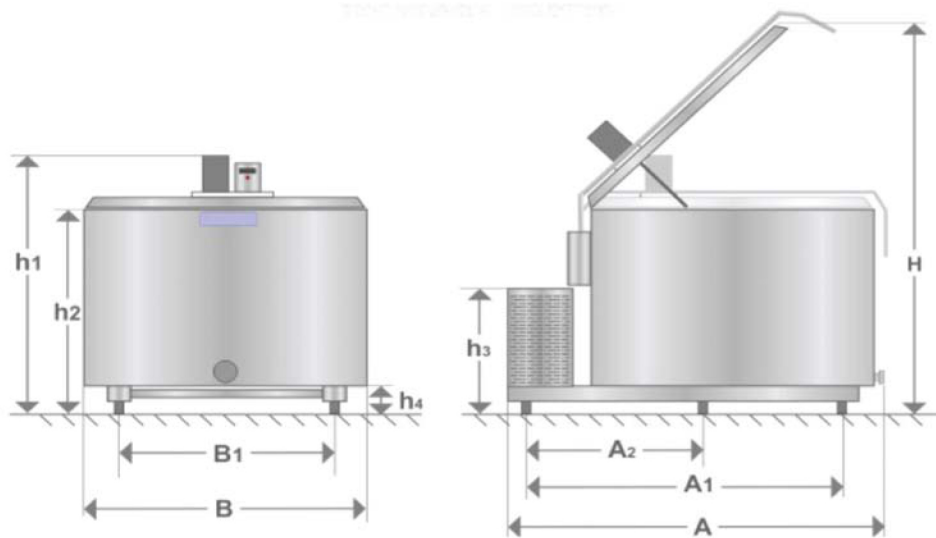

Dimensions in Inches

Tank Size	A	A ₁	A ₂	B	B ₁	H	h ₁	h ₂	h ₃	h ₄	H w/ Handle
112-Gallon	65.7	37.4	-	42.9	26.4	56.9	41.3	32.7	27.0	7.1	61.2
140-Gallon	63.8	37.4	-	42.9	26.4	63.8	46.8	38.0	27.0	7.1	67.1
170-Gallon	63.0	37.4	-	42.9	26.4	69.5	53.0	44.0	27.0	7.1	72.0
220-Gallon	84.3	64.2	-	50.8	36.4	68.5	49.8	40.9	27.0	7.6	78.1
285-Gallon	92.5	52.0	17.7	58.9	35.8	77.8	49.2	39.8	33.1	7.6	77.8

Technical Specifications

Tank Size	Max Capacity (Gallons)	Weight (lbs)	Voltage	Refrigerant	HP	BTU/hr	Amps	Max Amps
112-Gallon	114.7	385	220V, 1 Phase	R404A	1.5 HP	10557	9.9A	15.4A
140-Gallon	140.5	388	220V, 1 Phase	R404A	1.5 HP	10557	10.1A	16.0A
170-Gallon	174.1	445	220V, 1 Phase	R404A	2 HP	15604	10.7A	19.2A
220-Gallon	224.5	529	220V, 1 Phase	R404A	2.5 HP	25465	10.7A	18.1A
285-Gallon	282.6	595	220V, 1 Phase	R404A	3 HP	32026	19.8A	27.0A